

SR SCL OPW-2105

Installation Instructions

for
OPW 2105 Spill Containers



Diversified Products
Manufacturing Inc.

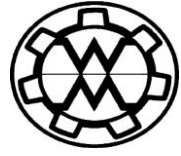

Weaver Products

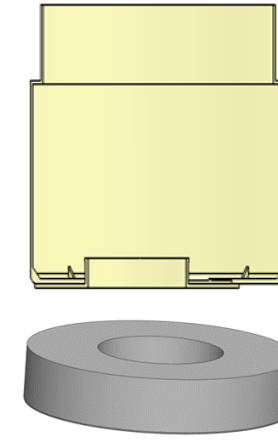
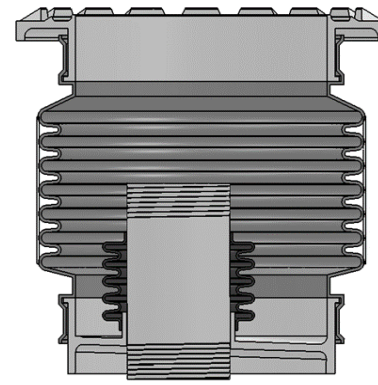

This spill containment repair Kit consists of

SCL-OPW-2105	Liner
SCL-OPW 2105 Spacer	Spacer
DBF II	1 each 20 oz. Dual Cartridge Set of Polysulfide Liquid w/ CH-SM-I Static Mixer
DBB V	1 each 50ml dual cartridge set of Methyl Methacrylate w CH-SM III Static mixer
DP3	Drain Plug
#72	4" Band Clamp
# 176	12" Band Clamp, Expandable Compression Ring
DBC II	1 each 12 oz. aerosol Cleaner
INI-SR SCL OPW-2105	Installation Instructions
C&B	1 each Cup and paint Brush
Gloves	Gloves - 2 Pair

Note: This kit consists of two ORMD products (DBC II and DBB V) For air shipments these items shall be shipped separately

Step 1

- 1) Remove Drain Valve
- 2) Remove Cap and Adaptor
- 3) Replace Riser if necessary to meet local codes
Riser, Adapter and replacement cap are not part of this repair kit
- 4) Replace drain plug with DP3 drain plug provided in this kit
- 5) Draw a line on the riser 4.5" above the bottom of the spill container.

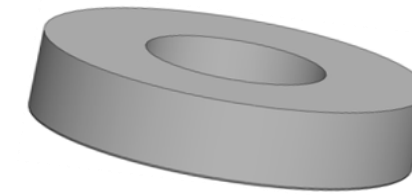
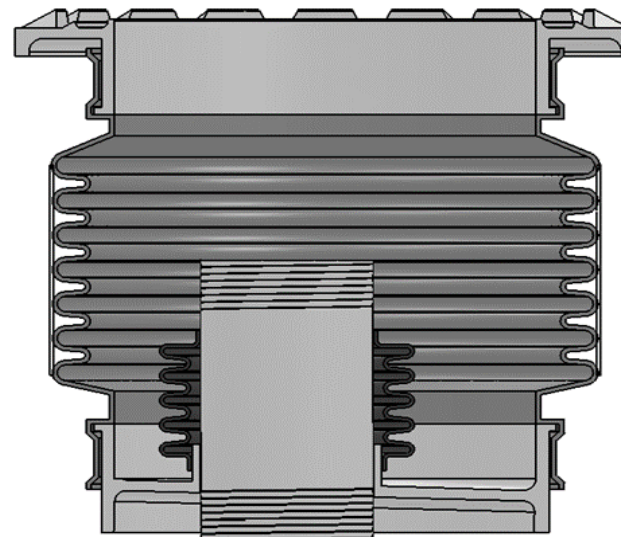
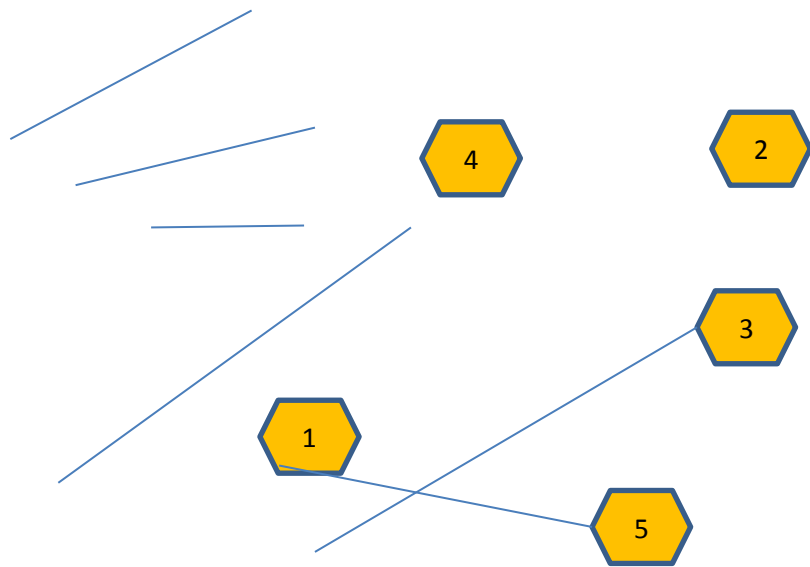

Step 2

- 1) Sand the inside of the snow plow ring below the lip.
- 2) Sand down 1.5" from the mark line on the 4" riser. Clean with CH-DBC II aerosol provided in the kit.
- 3) Remove protective strip from sticky-back tape on bottom of spacer and install spacer
- 4) Before filling the bottom of the spill container, fill the cup with CH-DBF II.
Save for use in step 5
- 5) Fill the bottom of the spill container with CH-DBF II until just covering the top of the bolts

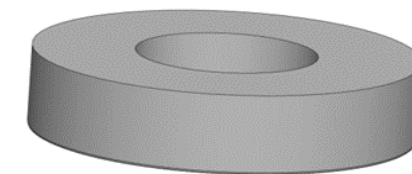
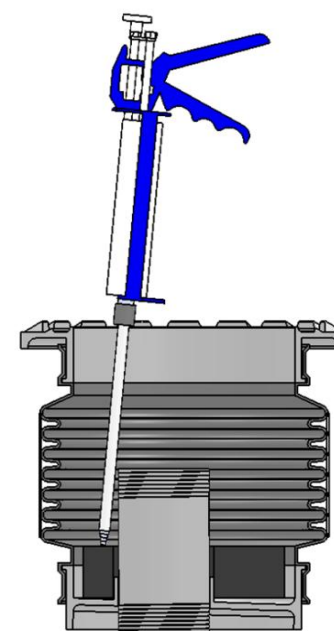
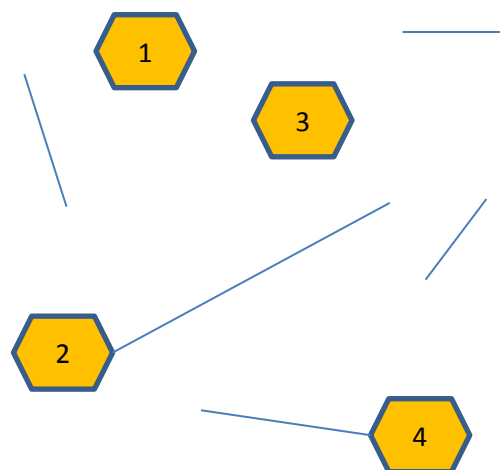

Step 3

- 1) Be sure the entire outer "upper" perimeter area is clean and dry. Spray with CH-DBC II aerosol and air dry or wipe dry with a clean dry cloth
- 2) Clean the surface of the liner section to be bonded. Follow instructions in step 1
- 3) Apply a thick bead of CH-DBB V around the 4" riser at about 1.5" above the fill level.
- 4) Collapse Liner and slide down into the spill container. **Install Liner Immediately**
- 5) Nest the bottom of the liner into curing CH-DBF II fill.

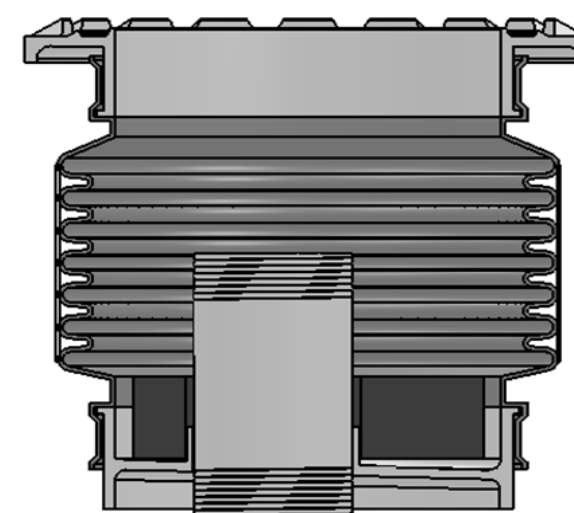
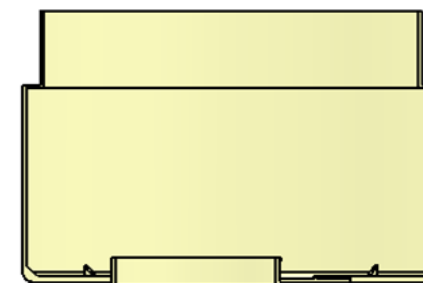
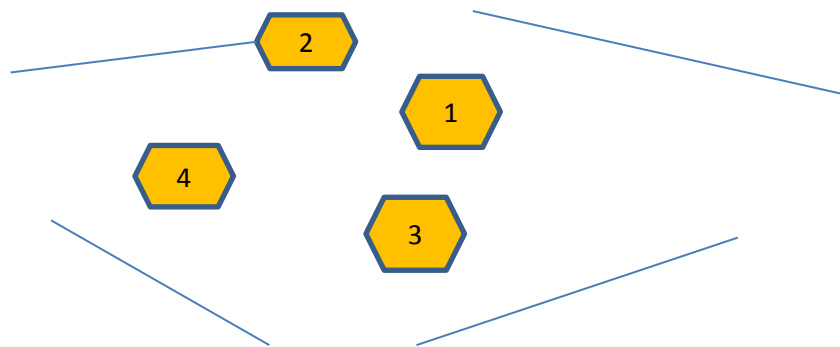

Step 4

- 1) Seat liner into CH-DBF II fill and install the band clamp. Top of liner should fit snug to the snow plow ring.
- 2) Pull back upper edge of liner and apply a healthy bead of CH-DBB V to seal upper edge of liner to the Snow Plow Ring
- 3) Install the "Expanding Compression Ring" (inverted band clamp) to hold liner while bonding agent cures
- 4) Leave 'expanding Compression ring' in place after curing
Be sure to install liner within 15 minutes of applying DBF II fill.

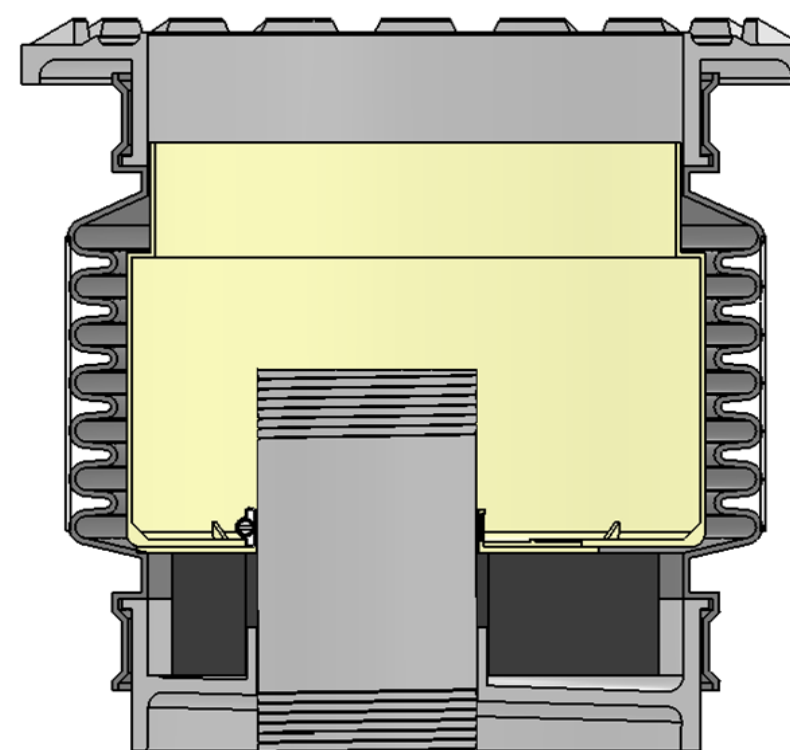
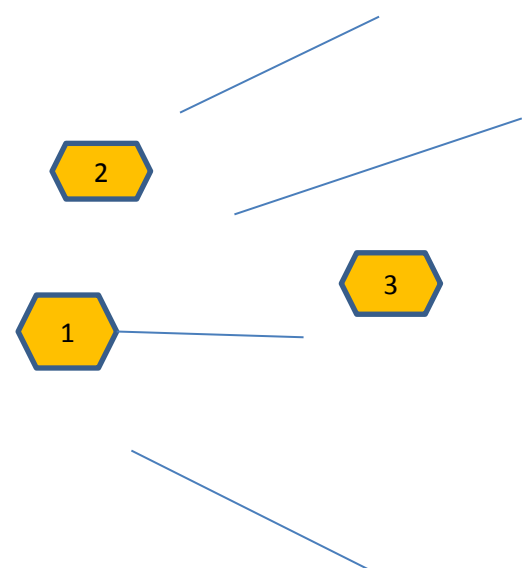

Step 5

- 1) Use the paint in the cup to paint around the top of the liner and around the riser where clamps are attached. Cover all exposed liner and any exposed CH-DBB V.
- 2) Reinstall the Adaptor and Cap
- 3) After 1 hour curing, spill container may be hydrostatically or vacuum tested per local requirements.

Clean Up: CH-DBC-II is an excellent cleaner that will remove polysulfide from tools.

